



"College Hill" Motorized Transaction Drawer

Improved Performance & Durability



HAMILTON
BY **GUNNEBO**[®]

"College Hill Motorized Drawer

The College Hill Motorized Transaction Drawer is an improved design that utilizes more common parts found within standard and commercial-size drawers.

Each drawer features a plug-and-play audio system and optional heater, eliminating the need for on-site wiring after installation. The new design offers a smaller footprint, making it an ideal replacement option without requiring modifications to existing masonry openings.

The drawer is perfect for passing small items between the customer and your team member. It is ideal for prescription containers and other small items, built with a rugged, high-performance stainless steel exterior for maximum security.

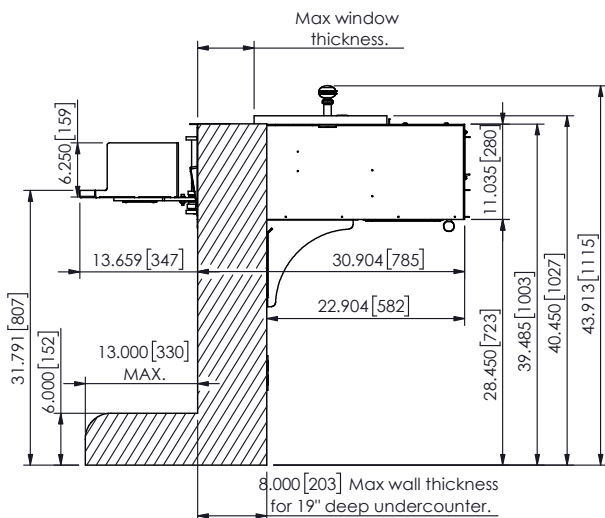
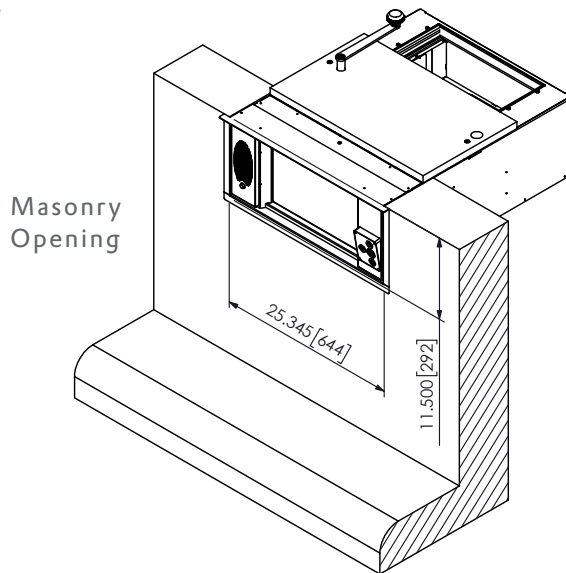

FEATURES

- CYCLED TESTED OVER ONE MILLION TIMES
- SMALLER FOOTPRINT BUT BIGGER PAYLOAD
15 3/8" W X 6 1/2" H X 8 1/8" D
- FACTORY-INSTALLED HANDSET OPTION
- FACTORY-INSTALLED VEHICLE DETECTION OPTION
- UL LISTED / LEVEL 3 BULLET RESISTANT
- SUSPENSION FREE DESIGN - NO RAILS
- ADJUSTABLE DRAWER EXTENSION FOR CAR DISTANCE

Plan View

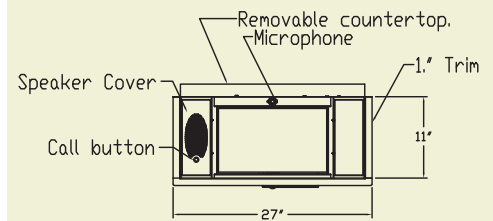

Includes:

Plug & Play Audio

Optional:

Plug & Play Heater, Vehicle Detection, Handset

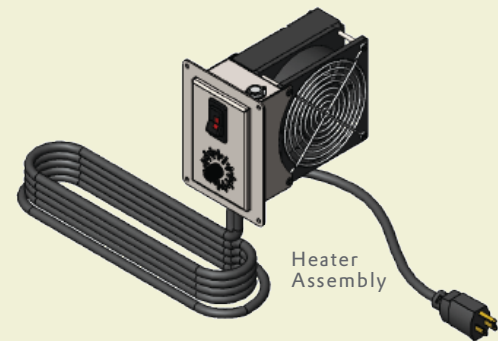

HAMILTON
BY GUNNEBO®

